

20 YARD Vacuum Roll Off Box

Vacuum Box rentals from Mobile Mini Tank + Pump are perfect for pairing with an air-mover vacuum truck which can vacuum up liquids, dry materials, mixtures of wet and dry materials, and sludge. Now your air-mover vacuum truck can operate even more efficiently by collecting the contents vacuumed in the roll-off vacuum box, allowing the air-mover truck to remain on-site and in-service during vacuum pumping applications.



Dimensions and Weights

Length: 23' 1 5/8"
Width: 8'
Height: 4' 11 3/8"
Capacity: 20 cubic yard
Tare Weight: 10,500 lbs

Construction

Floor: 1/4" A36 plate
Walls: 1/4" A36 plate
Long Sill: 6 x 2 x 1/4" tubing
Frame: 3/16" tubing

Features

Drain: Two 4" flanged drain
(curb and street)
Port: Two 8" (front and rear)
Manways: One 22" (roof)
Wheels: 10" steel

**Photos are representational; actual products vary. Additional product plans and specifications may vary from those shown and are subject to in-stock availability.*

Vacuum Box Drawing

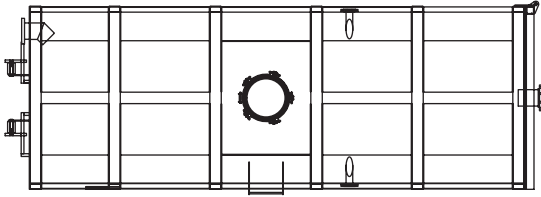

**Some details not shown in all views. Overall dimensions are normal.*

**Photos are representational; actual products vary. Additional product plans and specifications may vary from those shown and are subject to in-stock availability.*

Top View

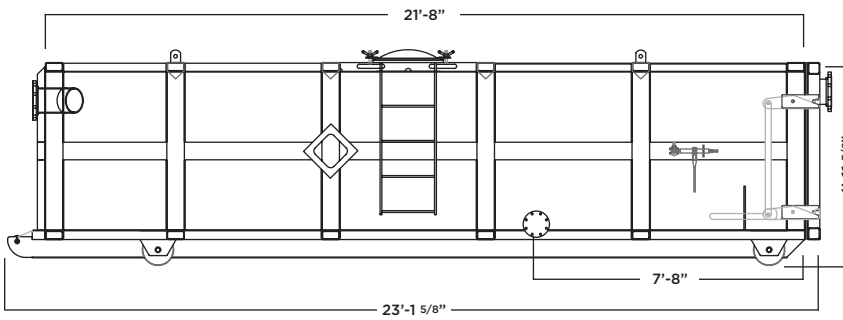

Side View

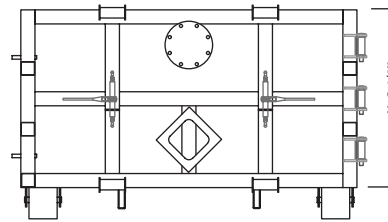
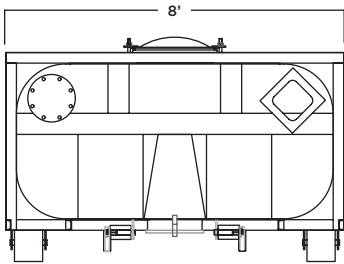

Front View

Rear View: